

A Contact Based Dynamic Delamination Buckling Analysis of Composites

S. Mohammadi¹ and A. Asadollahi²

Department of Civil Engineering, University of Tehran
Tel: +98-21-611 2273, Email: smoham&shafagh.ut.ac.ir

ABSTRACT

In this study, a combined finite/discrete element algorithm is developed to simulate delamination and inplane fracture in laminated composites subjected to dynamic loadings. The application of the finite/discrete element strategy to modelling of dynamic loading of composites is innovative, and will provide a significant advance in comparison to presently available capabilities of numerical modelling of this complex physical problem. In this method of modelling of composites, the possible delaminated region is modeled using a discrete element mesh, and the rest of the structure is modelled by a standard finite element mesh. Each group of similar plies is modelled by one discrete element. Each discrete element will be discretized by a finite element mesh and might have material or geometric nonlinearities. The interlaminar behaviour of discrete elements is governed by bonding laws which include contact and friction interactions for the post delamination phase. Once two layers are delaminated, the corresponding interface will still be capable of further contact and friction interaction. The performance of the model to correctly simulate the physical behaviour of composites subjected to impact loadings will be assessed by solving several test cases available in the literature.

KEYWORDS

Discrete element method, Dynamic Delamination buckling, Crack propagation, composites

INTRODUCTION

It is evident that impact loading can cause severe damage in composite laminates. The phenomenon of failure by catastrophic crack propagation poses problems in all applications, particularly in the aerospace industry in which safety is of paramount importance, but where over-design carries heavy penalties in terms of excess weight. Therefore, the development of reliable models for determining the failure behaviour of growing advanced materials are vitally important.

In general, according to the orthotropic laminated nature of composites, the failure modes may be classified into four different types : matrix failure, delamination, shear cracking, and erosion damage. There is, however, agreement that the most dominant causes of damage during impact are matrix cracking coupled strongly with complex mode delamination mechanisms Ambur[1995].

¹ Assistant Professor, corresponding author.

² Postgraduate student.

Numerical simulation of arbitrary shaped components is traditionally performed by the finite element techniques, which is rooted in the concepts of continuum mechanics and is not suited to general fracture propagation and fragmentation problems. In contrast, the discrete element method (DEM) is specifically designed to solve problems that exhibit strong discontinuities in material and geometric behaviour Munjiza[1995]. The discrete element method idealizes the whole medium into an assemblage of individual bodies, which in addition to their own deformable response, interact with each other (through a contact type interaction) to capture the characteristics of the discontinuum and to perform the same response as the medium itself.

In this paper, some of the main aspects of modelling of composites by DEM are discussed. The final summary and conclusions will follow some representative results of the numerical tests for assessing the performance of the method.

DISCRETE ELEMENT MODELLING OF COMPOSITES

Figure 1 shows a typical combined FE/DE mesh for a quarter of a composite plate subjected to concentrated central loading. In a combined FE/DE method, the fractured region is modelled using a discrete element mesh and the remainder of the specimen is modelled by a standard finite element mesh. A combined mesh enables us to prevent unnecessary contact detection and interaction calculations which comprise a major part of the analysis time Mohammadi[1997_3].

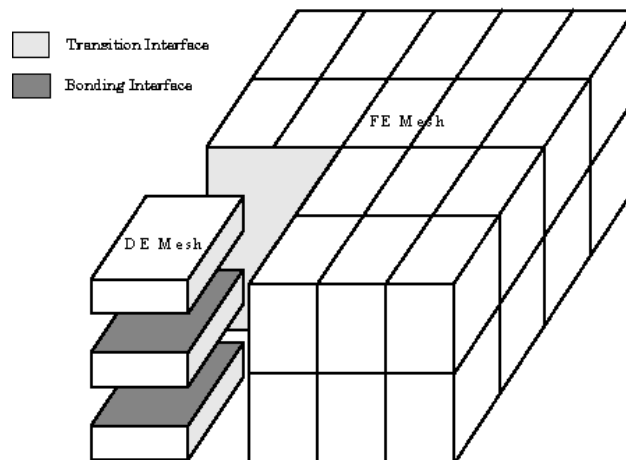

Figure 1: Combined FE/DE mesh

Each group of similar layers is modelled by one discrete element and each discrete element is discretized by a standard finite element mesh. The interlaminar behaviour of discrete elements is governed by bonding laws, including contact and friction interactions for the post delamination phase. Interactions between finite elements and discrete elements are modelled by transition interfaces (Figure 1).

Inplane fracture may result in the creation of new discrete bodies which are in contact and friction interaction with neighbouring bodies. A special remeshing algorithm is adopted to maintain compatibility conditions in newly fractured regions.

From the computational point of view, the discrete element procedure comprises three steps: object representation, contact detection, and contact interaction. The first two steps are closely associated to each other and are usually discussed within the framework of the contact detection algorithms.

Contact detection

An Alternating Digital Tree, Bonet[1991] contact detection algorithm is employed to detect the possibility of contact between discrete elements. In this method, each object is represented by a bounding box. Each bounding box is then represented by a space bisection algorithm resulting in a binary tree database structure. Figure 2 illustrates the space bisection procedure and the associated binary tree for a typical problem. The use of binary tree structure would dramatically increase the performance of contact search, because once one node of the tree is found to be sufficiently far from an object, all its descendant nodes will be eliminated from the contact search of that object.

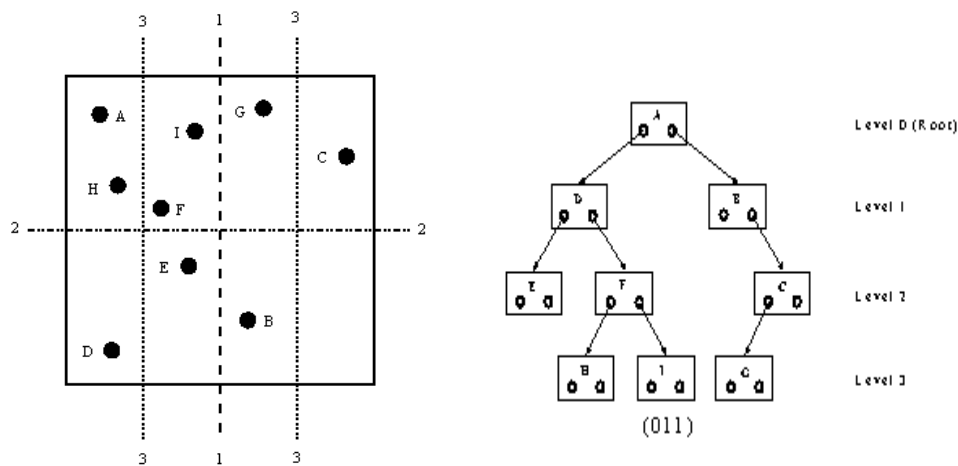

Figure 2: The space bisection approach, and its associated binary tree data structure.

Contact interaction

Once the possibility of contact between discrete bodies is detected, another method has to be used to satisfy the impenetrability condition of the bodies. Many different methods have been developed for enforcing a constraint condition on the governing equation of a well established physical behaviour. Among them the penalty method is likely to be the most appropriate scheme for adopting into an explicit contact analysis. In this method, penetration of the contactor object is used to establish the contact forces between contacting objects at any given time (See Figure 3).

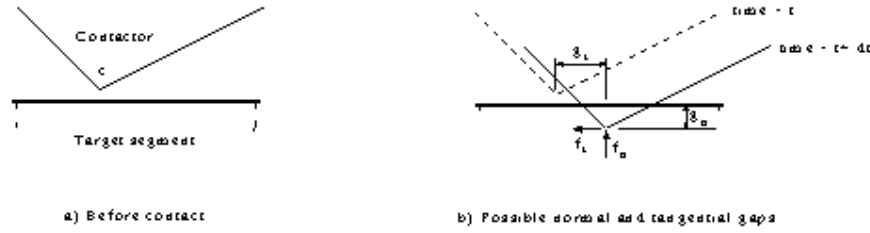

Figure 3: Contact force based on impenetrability.

According to the weak form of the boundary value problem, the component form of the virtual work of the contact forces associated to the contact node is given by Mohammadi[1998_1], Schonauer[1993]:

$$\delta W^c = f_k^c \delta g_k = f_k^c \frac{\partial g_k}{\partial u_i^s} \delta u_i^s$$

where $k=n,t$ and $i=x,y$, and u_i^s is the i -component of the displacement vector at node s , $\mathbf{g} = (g_n, g_t)$ the relative motion (gap) vector, and \mathbf{f}^c is the contact force vector over the contact area A^c ,

$$\mathbf{f}^c = \mathbf{A}^c \boldsymbol{\sigma}^c$$

$$\boldsymbol{\sigma} = \boldsymbol{\alpha} \mathbf{g} = \begin{bmatrix} \alpha_n & 0 \\ 0 & \alpha_t \end{bmatrix} \begin{bmatrix} g_n \\ g_t \end{bmatrix}$$

where $\boldsymbol{\alpha}$ is the penalty term matrix, which may vary between single contact nodes. The corresponding recovered residual force is then evaluated as:

$$r_i^s = f_k^c \frac{\partial g_k}{\partial u_i^s}$$

The calculated contact force has to be distributed to the target and the contactor nodes.

DELAMINATION INITIATION

The Chang-Springer criterion may be properly used for predicting the initiation of delamination.

Chang and Springer [1986_2]:

$$\left(\frac{\sigma_z^2}{N^2} \right) + \left(\frac{\sigma_{xz}^2 + \sigma_{yz}^2}{T^2} \right) = d^2$$

where N and T are the unidirectional normal and tangential strengths of the bonding material, respectively and failure occurs when d becomes greater than or equal to one.

MATERIAL MODEL

The imminence of material failure is monitored by the orthotropic Hoffman criterion, where a geometric yield surface is constructed from three tensile yield strengths σ_T , three compressive strengths σ_C , and three shear strengths σ_S . It may be defined as:

$$\Phi = \frac{1}{2} \boldsymbol{\sigma}^T \mathbf{P} \boldsymbol{\sigma} + \boldsymbol{\sigma}^T \mathbf{p} - \bar{\sigma}^2(\kappa)$$

where the projection matrix \mathbf{P} , and the projection vector \mathbf{p} are defined based on the nine material yield strengths and a normalized yield strength $\bar{\sigma}$ (see Schellekens et al. [1990]), and κ is a softening/hardening parameter.

A bilinear local softening model is also adopted in this study to account for release of energy and redistribution of forces which caused the formation of a crack. It may properly avoid the mesh dependency of the results by introducing a length scale into the softening material model Mohammadi [1997_3].

The additivity postulate of computational plasticity is used to formulate the rate form of the stress return algorithm. The integration of the flow rule in a finite step is then performed by the backward Euler method coupled with the Newton-Raphson iterative scheme.

NUMERICAL SIMULATIONS

The author has previously published a number of papers on verifying the performance of the approach in modelling the complex behaviour of progressive cracking in composites (Mohammadi [1997_3,1998_1], Owen[1998]). Therefore, in this paper only further numerical simulations of some engineering applications are presented.

Fracture and delamination buckling analysis of an orthotropic composite specimen is considered. The material properties used in the calculations are listed in Table 1 (Liu [1993]). The composite $[90_n, 0_n, 90_n]$ ply layout is assigned to the beam with (LHW=10.16,0.249,2.54cm) geometric descriptions. The specimen is subjected to quasi-static concentrated loading $P=2300$ KN applied at its centre line. An eight layer finite/discrete element mesh was used to model half of the beam.

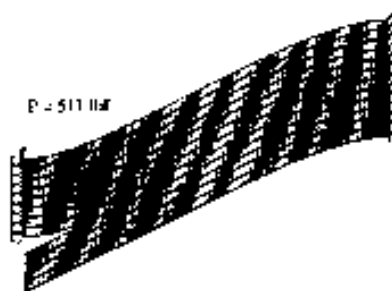
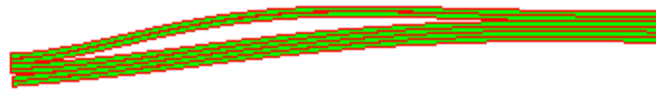

TABLE1
MATERIAL PROPERTIES OF THE ORTHOTROPIC COMPOSITE BEAM

$E_{xx} = 139200 \text{ M Pa}$,	$G_{xx} = 5580 \text{ M Pa}$
$E_{yy} = 9700 \text{ M Pa}$,	$G_{yz} = 3760 \text{ M Pa}$
$\nu_{xy} = \nu_{yz} = .3$,	$\rho = (1.38 \cdot 10^{-2}) \frac{\text{kg}}{\text{m}^3}$
$X_t = 1150 \text{ M Pa}$,	$X_c = 1120 \text{ M Pa}$
$Y_t = 40 \text{ M Pa}$,	$Y_c = 170 \text{ M Pa}$
$S = 100 \text{ M Pa}$		



(a) Buckling of top delaminated layer.}



(b) Fracture patterns

Figure 5: Deformed shape and crack patterns of the $[90_n, 0_n, 90_n]$ composite specimen.

Figure 5a illustrates the buckling mode of delaminated layer. Although Liu [1993] reported the same delamination patterns, however, no buckling mode was reported at the top delaminated interface.

A fracture analysis was also performed to predict the real damage loading and damage mode of the beam (Figure 5b). Matrix cracking across the thickness of the top layer of the specimen prevents the formation of a buckling mode and the overall behaviour of the specimen reduces nearly to an unbonded multi-layer beam.

Impact loading of a composite plate - delamination analysis

A numerical simulation is undertaken to assess the performance of the method for dealing with progressive debonding phenomena (no material fracture) in a laminated composite plate which is subjected to a high velocity impact at its centre (based on the experiments undertaken by Worswick [1995]).

Because of symmetry, only one quarter of the plate is modelled. Also, only the central region of this model is meshed by a DE mesh (See Figure 6). The composite ply pattern is set to $[90_n, 0_n, 90_n, 0_n, 90_n]$. The impact loading is simulated by a triangular load applied from 0 to 5 μsec with a peak force of 5 kN.

Material properties and other necessary information are given in Table 2.

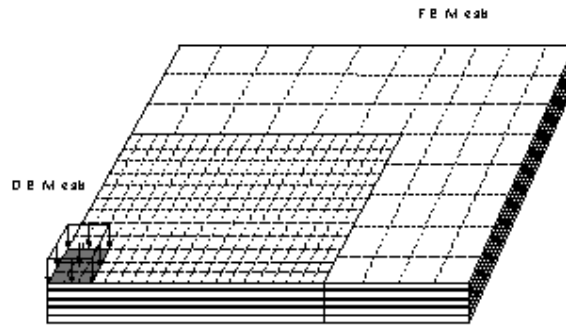

Figure 6: FE/DE mesh of the composite plate.

TABLE 2
MATERIAL PROPERTIES FOR T800/P2302-19 GRAPHITE RESIN

Model size = $0.0762 \times 0.0508 \times 0.0044$ m	
DE region = $0.05 \times .035$ m	
Ply layout [90, 0, 90, 0, 90]	
$E_{xx} = 152.4e3$ M Pa	, $E_{yy} = 10.7e3$ M Pa
$\nu = 0.35$, $\rho = 1.55 e3 \frac{kg}{m^3}$
$X_t = 2772$ M Pa	, $X_c = 3100$ M Pa
$Y_t = 79.3$ M Pa	, $Y_c = 231$ M Pa
S = 132.8 M Pa	

Figures 8 and 9 illustrate the debonding patterns at different layer interfaces for two different stages of the loading. Delamination patterns are clearly developing from the central region of the plate, i.e. the impacted zone, towards the edges of the plate.

Figure 7 depicts the comparison of the displacement history of the centre of the plate for this mesh and a coarser mesh. The comparisons are made for both the top and bottom point across the thickness of the plate, and clearly shows the mesh independency of the results.

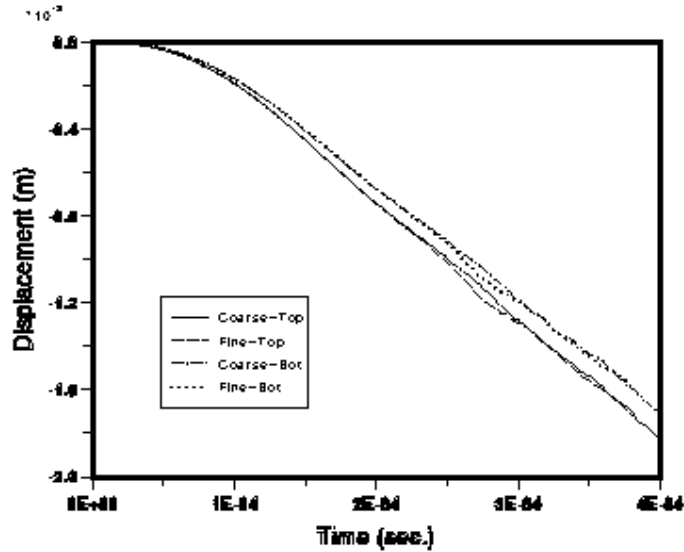

Figure 7: Displacement history of the central point

CONCLUSIONS

The combined finite/discrete element has proved to be an efficient algorithm for dealing with multi-fracture and fragmentation processes, which frequently arise from impact loadings on structures. An alternating digital tree method is adopted to reduce the extensive numerical costs of the contact detection phase. A local remeshing scheme is introduced for geometric modelling of the cracks, which plays an important role in avoiding the excess distortions of the finite elements in the vicinity of cracks. Several numerical tests have been used to assess the performance of the method.

ACKNOWLEDGEMENTS

The authors would like to appreciate Prof. D.R.J. Owen and Dr. D. Peric, from University of Wales Swansea, who were closely involved in the developing stage of the work.

REFERENCES

- Ambur.D.R and Starnes.J.H (1995). Low- speed impact damage-initiation characteristics of selected laminated composite plates. *AIAA Journal*, **33:10**,1919-1925.
- Bicanic.N, Mungiza .A , Owen.D.R.J, and Petrinic.N.(1995). From continua to Discontinua- a combined finite element / discrete element modeling in civil Engineering . In Topping.B.H.V , editor , *Developments in Computational Techniques for Structural Engineering*, pages 45-58 ,Civil-CompPress.
- Bonet.J and Peraire.J.(1991). An alternating digital tree (adt) algorithm for 3d geometric searching and intersection problems . *International Journal for Numerical Methods in Engineering* **31**,1-17.
- Chang .F.K and Springer.G.S. (1986) .The strength of fiber reinforced composite bends. *Composite Materials* **20:1**, 30-45 .

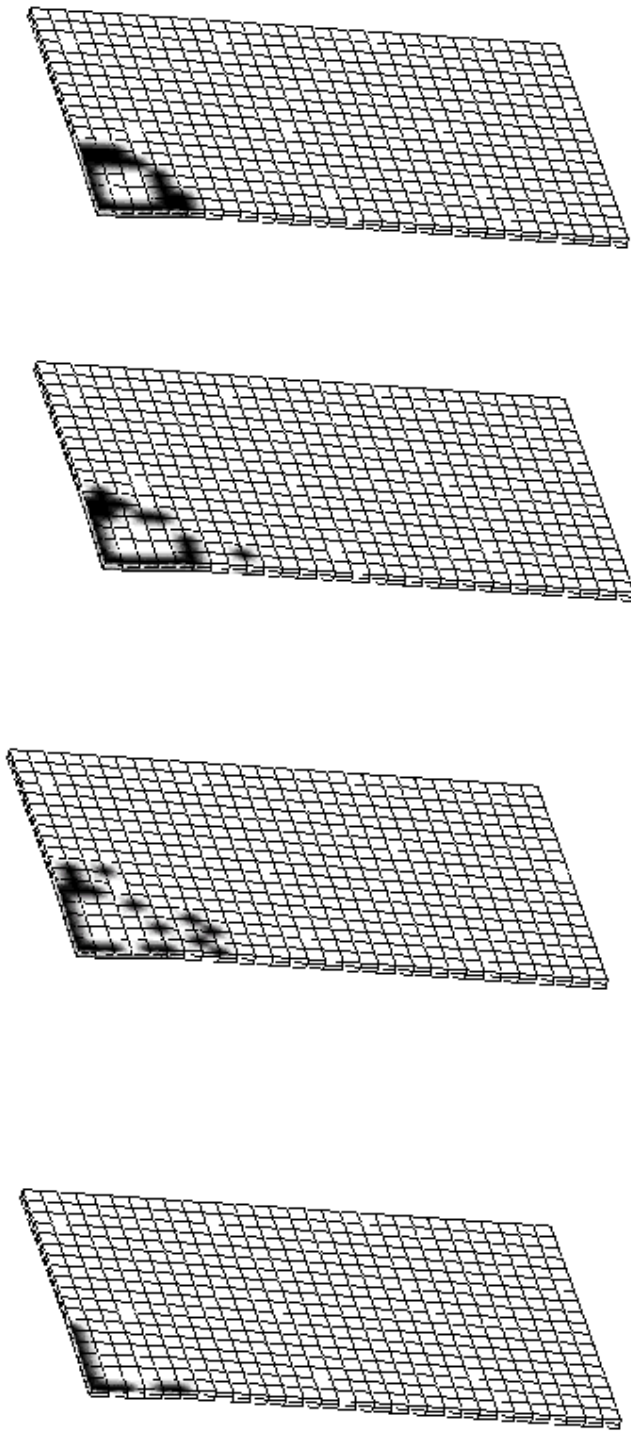

Figure 8: Delamination patterns at layer interfaces at $T=0.00006$ sec.

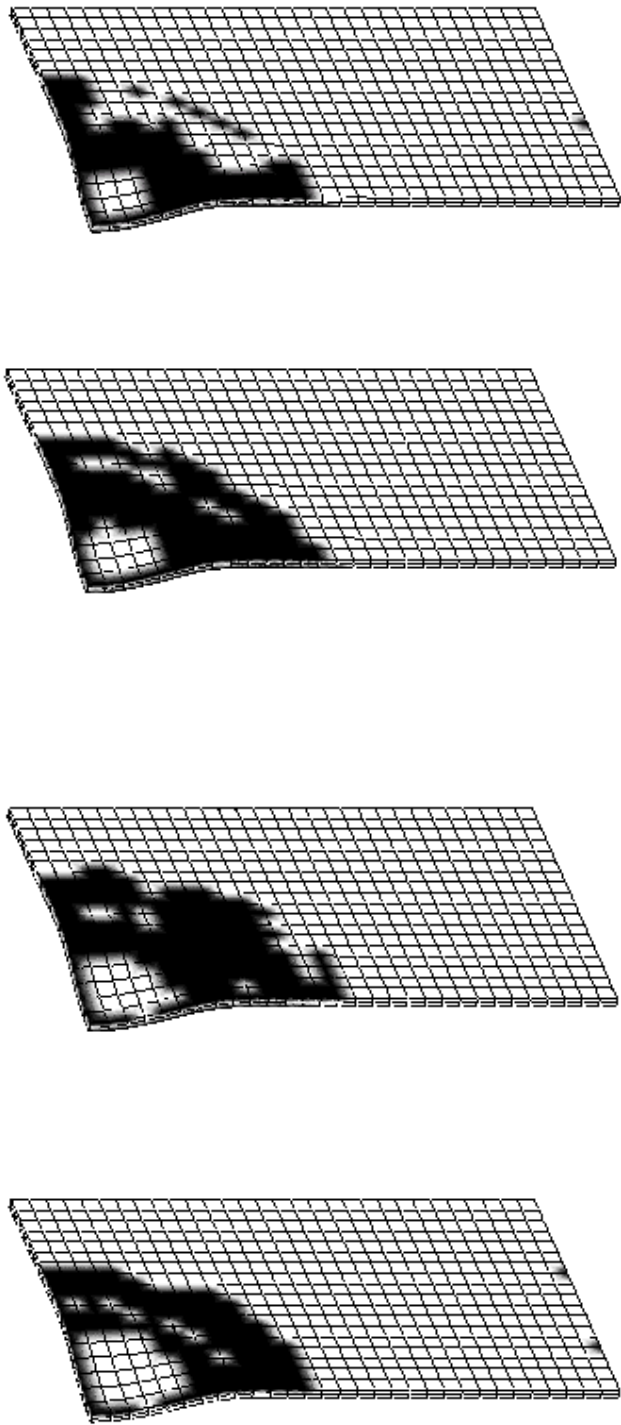

Figure 9: Delamination patterns at layer interfaces at $T=0.00012$ sec.

- Hallquist.J.O , Goudreau.G.L, and Benson.D.J .(1985). Sliding interfaces with contact-impact in large scale lagrangian computations .Computer Methods in Applied Mechanics and Engineering,**51**.
- Lagace.P.A and Wolf.E. (1995) . Impact damage resistance of several laminated material systems. *AIAA Journal*, **33:6**, 1106-1113
- Liu.S, Kutlu.Z, and Chang.F.K.(1993). Matrix cracking-induced delamination propagation in graphite/epoxy laminated composites due to a transverse concentrated load . In Stichcomb.W.W and Ashbange.N.E, editors , Composite Materials : Fatigue and Fracture, ASTM STP 1159, volume 4, pages 86-101 ,Damage analysis of composites . In Crisfield.M .A , editor, Computational
- Mohammadi. S, Owen.D.R.J , and Peric.D .(1997). Discontinuum approach for Mechanics in UK- *5th ACME Conference* , pages 40-44 ,London,UK.
- Mohammadi.S, Owen.D.R.J , and Peric.D.(1998). A combined finite / discrete element algorithm for delamination analysis of composites. *Finite Elements in Analysis and Design*,**28**,321,336.
- Mohammadi .S , Owen.D.R.J , and Peric.D.(1997) Delamination analysis of composites by discrete element method. In Owen.D.R.J, Onate.E , and Hinton .E, editors , Computational Plasticity , COMPLAS V, pages 1206-1213, March 1997. Barcelano ,Spain.
- Mohammadi .S , Owen.D.R.J and Peric.D .(1997).3D fracture analysis of composites by DEM. In M.S. Shephard.M.S, editor , *Fourth US National Congress on Computational Mechanics*,page 539. USACM, SanFrancisco,USA
- Munjiza.A , Owen .D.R.J, and Bicanic.N. (1995). A combined finite -discrete element method in transient dynamics of fracturing solids . *Engineering Computations*,**12**,145-174.
- Owen. D.R.J , Peric.D , and Mohammadi .S .(1998). Discrete element modeling of multi – fracturing solids and structures. In Foreign Object Impact and Energy Absorbing Structure, pages 50-67. Institution of Mechanical Engineers (IMEchE) , Aerospace Industries Division.London.
- Petricin.N.(1996) Aspects of Discrete Element Modeling Involving Facet-to-Facet contact Detection and Interaction . *PhD thesis*, Department of Civil Engineering,Univercity of Weles Swansea,UK.
- Rowlands.R.E.(1985). Strength (failure) theories and their experimental correlation .In Sih .G.C and Skudra.A.M , editors, Handbook of Composites,Vol. 3,*Failure Mechanics of Composites* , chapter 2,pages 71-125 .Elsevier Science Publishers B.V.
- Schellekens .J.C.J and de Borest.R.(1990). The use of hoffman yield criterion in finite element analysis of anisotropic composites. *Computers and Structures* **37:6**,1087-1096.
- Schonauer.M, Rodic.T, and Owen.D.R.J . (1993). Numerical modelling of thermomechanical prosseses related to bulk forming operations . *Journal De Physics IV* **3**,1199-1209.
- Worswick .M.J, Strazincky.P.V, and Majeed .O.(1995).Dynamic fracture of fiber reinforced composite coupons. In Sun.C.T, Sankar.B.V, and Rajapakse .Y.D.S, editors, Dynamic Response and Behavior of Composites , *ASME*, AD-**46**, 29-41